

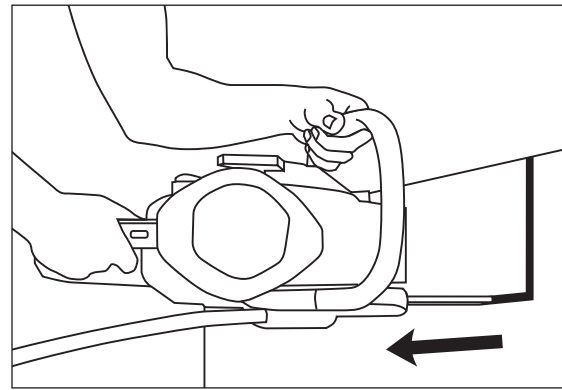

CUTTING TIPS

MAKING YOUR FIRST CUT:

1. **Outline the cut** with a permanent marker.
2. **Start the saw and after a brief warm-up period, rev and hold the trigger on full throttle.** Always use full throttle when cutting. Refer to “Starting the Saw” tip sheet.
3. **Carefully align the nose of the bar with the cut line**, slowly touch the wall with the chain and plunge straight into the wall.

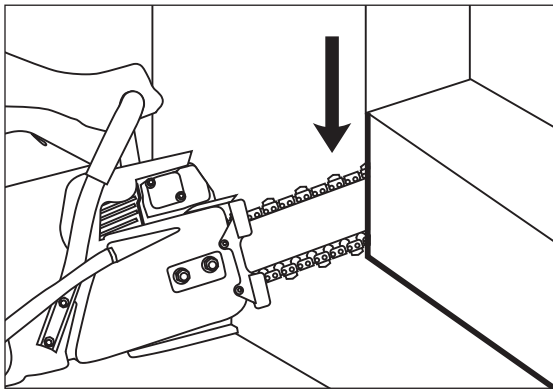

4. **Push hard enough so that the engine RPM drops 20 to 30%.** If the chain is stalling in the cut, you're pushing too hard. If there is very little difference between free running full RPM and the cutting RPM, you're not pushing hard enough. Listen for the “sweet spot” and maintain that RPM throughout any cut.
5. **Keep steady, firm pressure on the saw as the chain is cutting.** This will prevent chain bounce and chattering and help extend diamond life. Minimize arm motions.
6. **Use the WallWalker® to make cutting easier.** Insert the point of the WallWalker® into the cut and pull up on the rear handle. If saw is equipped with rubber pad WallWalker®, use the rubber pad for leverage in the same way.

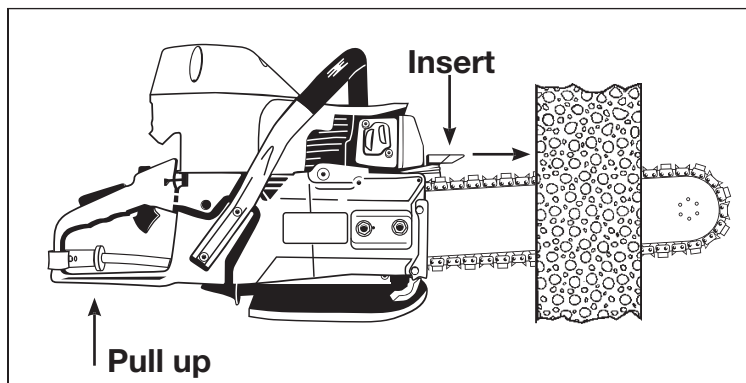

CUTTING TIPS

ADDITIONAL CUTTING TIPS:

- a. **For the straightest cuts use the Step Cut method.** After outlining the cut, score the entire cut line approximately a half-inch deep using the nose of the bar. Next deepen cut by about two inches. Then plunge all the way through and complete the cut using the WallWalker® as a lever.
- b. **Plunge cut instead of starting on top of a wall.** Plunge cutting generally results in a straighter start. If the cut doesn't start straight, it will not finish straight. Also, plunging is the fastest and easiest mode of cutting.

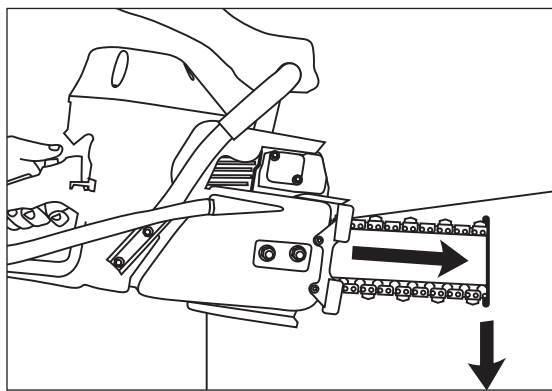

- c. **When cutting heavy rebar.** Slowly rock the saw over the rebar, maintaining gray slurry water, so that you're always cutting concrete as well as steel. This will help keep the diamonds exposed. Also, expect less chain life when cutting heavy rebar.
- d. **Maintain proper chain tension.** The tensioning rule of thumb for a chain-based cut-off saw is that the chain should be tight but must be able to be pulled around the bar by hand. See "Chain Tensioning" tip sheet.
- e. **If the saw begins to cut consistently crooked.** Turn the guide bar over and use the other side. If problem persists, dress the worn rails with belt grinder. Note: The normal life of a guide bar is 2 to 3 chains. Heavy rebar can shorten bar life.
- f. **When using a new chain, it may be necessary to open up the diamonds.** To do this, make a few cuts into an abrasive material like a cinder block. Opening the diamonds will increase the cutting speed.

